

Spraytech Systems Flow Nozzle is used in typically high-velocity, non-viscous, erosive flow. They are suitable for determining the flow rates of fluids at high temperature and high pressure.

Spraytech Systems Flow Nozzles are erosion-resistant, consistently accurate and virtually maintenance-free. They perform a wide variety of applications that include air, water, steam, gas, chemical substances and high temperature applications. The Rounded design provides a more effective sweep-through of particles in the flow stream, which extends product life by reducing wear and potential damage. Flow Nozzles are manufactured in strict accordance with ASME MFC-3M, BS-1042 and ISO-5167 standards. For critical measurement applications, wet calibration at reputed flow laboratories can be offered. Also we have an IBR approval for our manufacturing unit hence we can provide IBR form IIC certificate for flow nozzles.

Flow Nozzles have a smooth elliptical inlet leading to a throat section with a sharp outlet. Restriction in the fluid flow causes a pressure drop, which relates to the flow rate by applying Bernoulli's equation. The smooth inlet of the flow nozzle results in a higher coefficient of discharge than most other differential meters. This higher efficiency means greater flow capacity when compared to most other differential meters of the same size.

There are three types of Flow Nozzles

- ISA 1932, with corner taps
- ASME long radius, low beta ratio ($0.25 < \beta < 0.5$), with throat tap
- ASME long radius, high beta ratio ($0.25 < \beta < 0.8$), with radius taps (D & $D/2$)

ASME long radius, low beta ratio Nozzle with throat taps is used in steam turbine performance test As per ASME PTC-6 code.

ISA-1932 nozzle can be mounted with carrier ring or in between flanges with corner taps.

Long radius nozzles are normally with weld –in branch pipe with radius taps, Can be also mounted in between flanges.

To avoid welding of dissimilar metals, nozzles are also installed in the pipe with holding ring.

Salient features & benefits

- Widely used for high pressure & high temperature steam flow
- Useful for flow measurement at high velocities
- Rounded Inlet not subject to wear or damage, extending product life
- Better sweep-through effect for debris and liquids, eliminate damming effect
- Lower susceptibility to erosion
- Extended product life with no moving parts

HOLDING RING TYPE FLOW NOZZLE

These types of nozzles are designed for installation in a pipe without flanges. The flow nozzle is installed with the help of holding ring and locating pins which are made of same material as that of pipe thereby eliminating welding of dissimilar materials.

FLANGED TYPE FLOW NOZZLE

These types of nozzles are the most commonly used for insertion between pipe flanges. This type of nozzle is designed for pipe wall taps whose locations are determined by Beta ratio and pipe.

WELD-IN TYPE FLOW NOZZLE

This type of nozzle has a machined tongue around its greatest diameter designed to fit between bevelled ends of both inlet and outlet pipe section. The pipe sections, with the nozzle in place are firmly clamped and welded. The weld-in flow nozzle is used where flanges are not applicable such as high temperature and pressure applications in power plant installations, feed water, etc.

FLANGED TYPE THROAT-TAP FLOW NOZZLE

Flange type throat-tap flow nozzle is used when extreme accuracy and repeatability required. In most cases this type of nozzle is purchased with a complete flow section and laboratory flow calibrated. These types of nozzles are manufactured in strict accordance with ASME performance test code PTC-6.

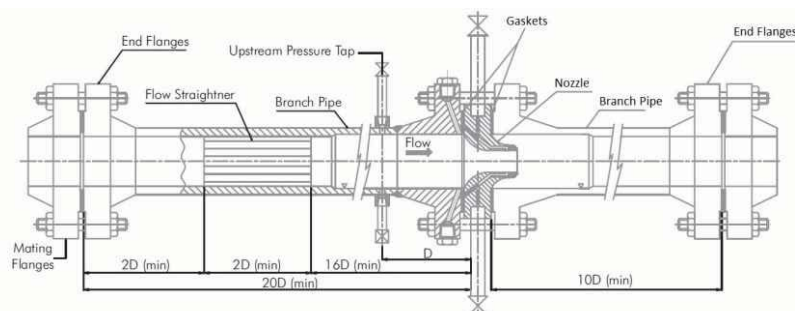

Flow Nozzle Assembly as per ASME PTC-6